



세계일류상품

C클라이머[®] CLIMBER PRODUCT LINE

C클라이머리프트[®]
CLIMBER LIFT

C클라이머엘리베이터[®]
CLIMBER ELEVATOR

세계최초 자체구동 신개념 승강기



송산특수엘리베이터
SONGSAN SPECIAL ELEVATORS

C클라이머[®] CLIMBER[®] PRODUCT LINE

C클라이머리프트[®] CLIMBER LIFT[®] C클라이머엘리베이터[®] CLIMBER ELEVATOR[®]

특장점

- ▶ 기계실이 없는 카 자체구동형 로프식 특허 혁신기술
- ▶ 운행 높이를 간단하게 높여서 사용하는 모듈 시스템
- ▶ 고속 저소음 저진동 가장 정숙하고 안전한 운행
- ▶ 이설 및 증설이 자유롭다

안전장치 PATENTED SAFETY EQUIPMENTS

적재하중 검출 모니터링 장치
중량초과 계측 제어장치
적재중량 로드셀 검출장치

Load Weighing Device & Monitor
Load Cell Device



고하중용 로프 브레이크
Heavy Duty Rope Brake Safety.



오버스피드 가버너 및 비상정지장치
Over Speed Governor and
Heavy Duty Safety Device



고하중 적재 처짐방지 안전 시스템
Car Anti Creeping Device

편하중 수평검출 안전 시스템
Tilting Safety Device



고하중용 세프티 완충기
Heavy Duty Safety Buffer



카 수평 안전 틸팅 장치
Car Tilting Safety Device

중량물 편하중 적재시 카의 기울어짐을 감지하여 위험 상태를 사전에 방지하는 안전장치



풍속관제 안전운전 시스템
디지털 풍속계 및 모니터링

Wind Safety control system
Digital wind Speedmeter & Monitor



고하중용 안전 제동장치
Heavy Duty Main Brake



자동식 램프 및 안전난간

Safety Staircase & Anti Slip Auto Ramp
지게차 탑승 경사로 및 일체형 안전계단 (선택사양)
Ramp for Forklift and Staircase
피트형은 불필요
No needed for pit type.



기술자료

TECHNICAL INFORMATION

표준설계제원표 | Standard Duty Tables

Capacity (ton/person)	3 ton	5 ton	7.5 ton	10 ton	20 ton	30ton	40ton	50ton	
	40p	65p	100p	150p	300p	450p	600p	750p	
Speed	60~180(0.5~3.0)			30(0.5)	45(0.75)	90(1.5)			
DRIVE SYSTEM	Car Self-Driving Wire Rope CLIMBER								
CONTROL SYSTEM	AC-VVVF INVERTOR VECTOR CONTROL								
TYPE OF CLIMBER	A,C	A	A	A,B					
Car Inside (mm)	W	1500	2400	3000	4000	6000	7000	8000	8000
	D	4500	5000	5500	5000	6000	7000	8000	9000
Door Opening (mm)	W	1500	2400	3000	4000	6000	7000	8000	8000
	H	2800	3000	3200	3500	3600	4000	5000	6000
DOOR TYPE	<input type="checkbox"/> 2-UP <input type="checkbox"/> 3-UP <input type="checkbox"/> 2-S <input type="checkbox"/> 3-S <input type="checkbox"/> 2-C <input type="checkbox"/> 4-C <input type="checkbox"/> 6-C								
Max. Height	500M								
Usage	Passenger & Freight								
Wind Speed	Designed Wind Speed <input type="checkbox"/> 30Mps <input type="checkbox"/> 40Mps <input type="checkbox"/> 50Mps								
Patent	Patented SONGSAN Only								
Location	<input type="checkbox"/> In Door				<input type="checkbox"/> Out Door				
M/C Room	No Needed								
PIT(mm)	300~800 (No Pit Ramp)				500~1200(No Pit Ramp)				

Min. Capacity : 3 ton, Max. Capacity : 100 ton

Note : • 위 표준제원은 고객의 요구에 따라 변경 적용이 가능합니다.
 These specifications above are possible to be changed by customer's requirement anytime.
 • T.B.D : To Be Determined based on the site.
 • 출입구 직각관통형(선택사양)
 Rectangular entrances(Optional)
 • 위 표준설계제원표, MAST, STRUCTURE는 현장여건, 적용치수, 적용사양 등에 따라 구조변경 적용 될 수 있습니다.

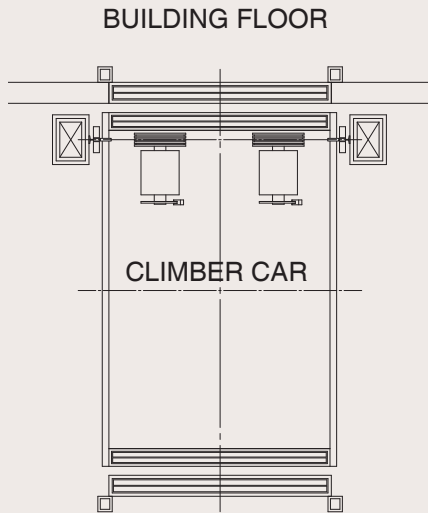

GROUND FLOOR

A Type

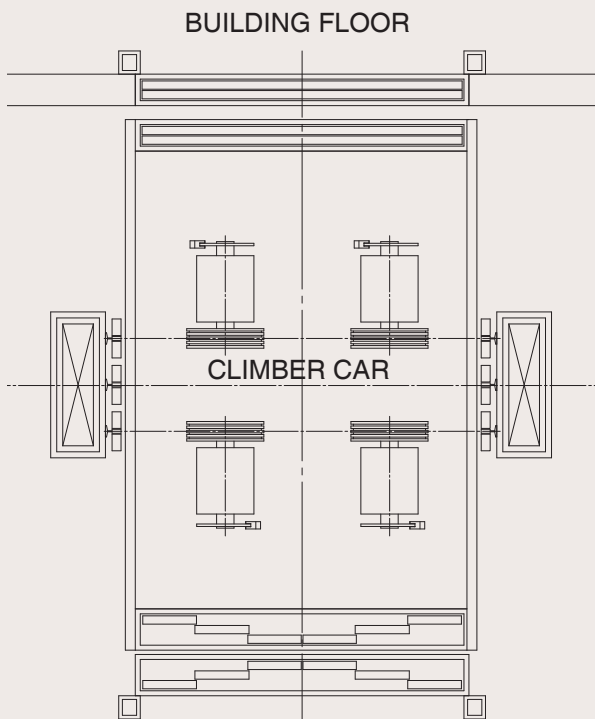

GROUND FLOOR

B Type

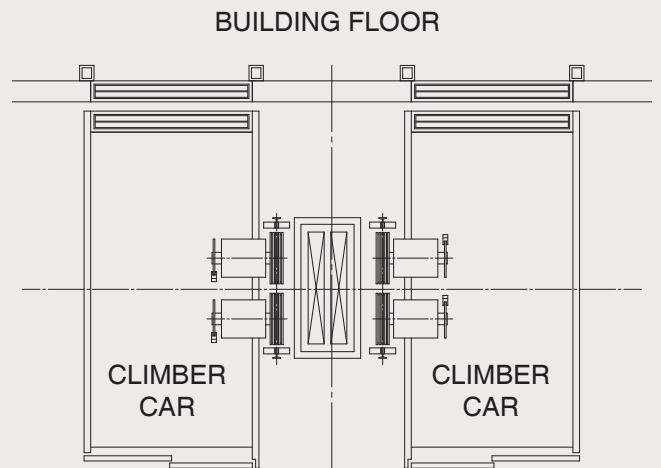

GROUND FLOOR

C Type

C클라이머[®] CLIMBER PRODUCT LINE

C클라이머리프트[®] CLIMBER LIFT

- ▶ PASSENGER & FREIGHT FOR CONSTRUCTION
- ▶ SEMICONDUCTOR & DISPLAY FACILITIES
- ▶ LARGE EQUIPMENTS LIFTING
- ▶ OFF-SHORE PLANT & SHIPYARD
- ▶ MINE, PETROCHEMISTRY
- ▶ LARGE SIZE LOGISTICS & WARE HOUSE
- ▶ EMERGENCY EVACUATION
- ▶ FIRE TRUCK LIFTING
- ▶ SHIP, AIRCRAFT CARRIER & MILITARY PURPOSES
- ▶ CAR, HELICOPTER, TANK TRANSPORTATION & SPECIAL PURPOSE
- ▶ NUCLEAR POWER PLANT, BRIDGE & HIGH RISE TOWER
- ▶ INCLINED TRANSPORTATION

C클라이머엘리베이터[®] CLIMBER ELEVATOR

- ▶ PASSENGER
- ▶ PASSENGER & FREIGHT
- ▶ HOSPITAL
- ▶ FREIGHT
- ▶ VIP HOME ELEVATOR
- ▶ AIRCRAFT, 2 STAGEBUS, SHIP, SUBMARINE
- ▶ BRIDGE & TOWER INSPECTION
- ▶ INCLINED ELEVATOR
- ▶ SPECIAL PURPOSE

